

PACIFICHEM™

CORROSION RESISTANT PUMPING

PACIFICHEM™



/ THE PACIFICHEM RANGE OF NON-METALLIC PUMPS

These pumps were developed to take maximum advantage from the key features of a group of synthetic thermosetting resins. The resins used are characterised by excellent resistance to chemical attack, strength and hardness comparable with many metals, and a good resistance to abrasion from fluid borne abrasives. A range of resins is used to gain optimum chemical resistance to the many fluids and chemicals encountered in industry.

The Pacifichem product provides then a cost-effective alternative for many processes which would normally require the use of exotic metal alloy or plastic lined pumps. Equally, other more innocuous but nonetheless troublesome fluids such as chlorinated water and seawater are handled with ease and with useful economy.



/ DESCRIPTION

/ MATERIAL FEATURES

Broadest range of chemical resistance for full operational coverage

Suitable for process temperatures from -20°C to +140°C

Excellent strength and hardness
Resists erosion in chemical slurries

Non-Sparking and non-galling
Beneficial in solvent applications

Does not support bacterial growth and can be steam sterilised

Relatively low mass reduces component weight

Low vibration and noise due to inherent attenuating properties of resin

Low cost when compared with exotic metals and advanced thermoplastics

/ TYPICAL PROCESSES

- Fume scrubbing
- Chemical manufacturing and processing
- Fertiliser manufacture
- Metal refining
- Metal finishing
- Municipal recreation pools
- Desalination plants
- Aquaculture and marine aquariums

02



1 / CLOSE COUPLED

Reliability has long been accepted as being inversely proportional to the number of components in any system. Quality close coupled pumps have used this principle to improve reliability in many industries and over the last 10 years Pacificchem have been successfully using the configuration in 90% of the toughest chemical duties. The Mk II close coupled provides a cost effective, compact solution to most industrial chemical applications

2 / LONG COUPLED

For many operators the use of any but this traditional layout is not an option. The ability to separate the hydraulic and prime mover elements provides tempting convenience and economy for many large sites. Pacificchem assist the cause of those choosing to hold with tradition by providing power-end and base plate in the same corrosion resistant resins as the wet-end.

3 / BELT DRIVEN

Even in the 21st century belt driving pumps carries advantages for some, with more accurate tailoring of curves to duties and the option of readily revising curves for those changing or indeterminate duties that make final decisions so difficult. Advantage is also to be derived from the safety from flooding that an over-mounted belt drive can provide in bund installations.

Fig. 1 / CLOSE COUPLED

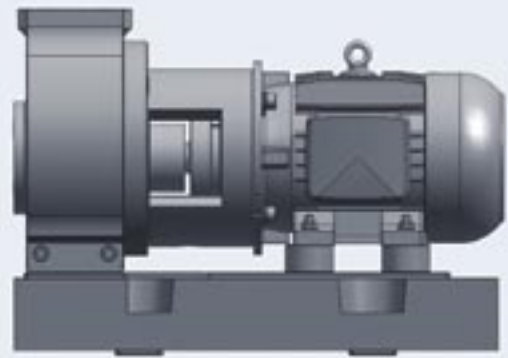

Fig. 2 / LONG COUPLED

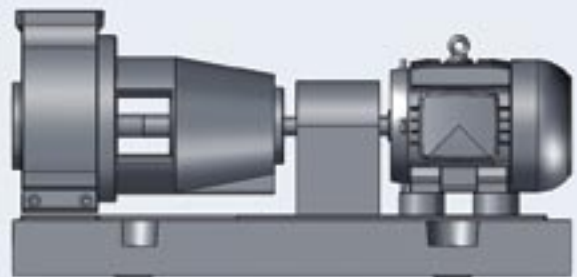
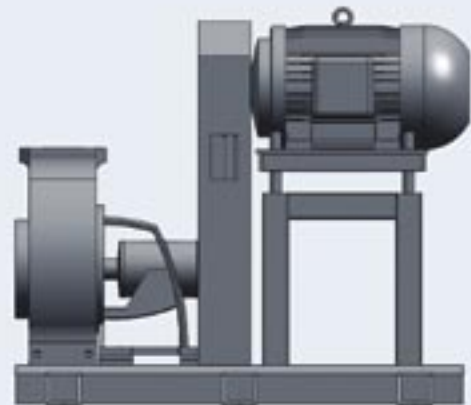

Fig. 3 / BELT DRIVEN



/ CONFIGURATIONS (4-5)

4 / CHEMICAL ROAD TANKER

The Pacifichem road tanker pump provides the chemical transport industry with a pump package that will handle almost any chemical they need to move. Driven by either a premium brand 13hp petrol engine or a hydraulic motor and PTO package, this pump represents the most cost effective and reliable solution to an extremely difficult duty

5 / VERTICAL SPINDLE

The VS series vertical spindle pump has a specialised role in chemical pumping. Because this pump operates with its volute and impeller immersed directly in the supply or process tank. It is often the most convenient method of achieving NPSHR in challenging applications. The absence of a mechanical seal means that the VS will happily run without product, making it particularly convenient for those processes in which it is difficult to guarantee reliable process fluid supply. This feature can even be utilised to advantage in those circumstances where top access to a tank is not available, by side-mounted hard-piping of the pump to the tank at an appropriate level. This unit is, of course, produced with all wetted components in our thermo-setting synthetic resin materials and is available in a useful range of sizes.

Fig. 4 / CHEMICAL ROAD TANKER

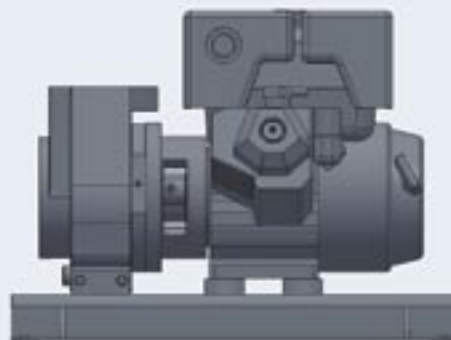

Fig. 5 / VERTICAL SPINDLE



/ CRP VS VERTICAL

The VS series vertical spindle pump has a specialised role in chemical pumping. Because this pump operates with its volute and impeller immersed directly in the supply or process tank. It is often the most convenient method of achieving NPSHR in challenging applications. The absence of a mechanical seal means that the VS will happily run without product, making it particularly convenient for those processes in which it is difficult to guarantee

reliable process fluid supply. This feature can even be utilised to advantage in those circumstances where top access to a tank is not available, by side-mounted hard-piping of the pump to the tank at an appropriate level.

This unit is, of course, produced with all wetted components in our thermosetting synthetic resin materials and is available in a useful range of sizes.

/ FEATURES

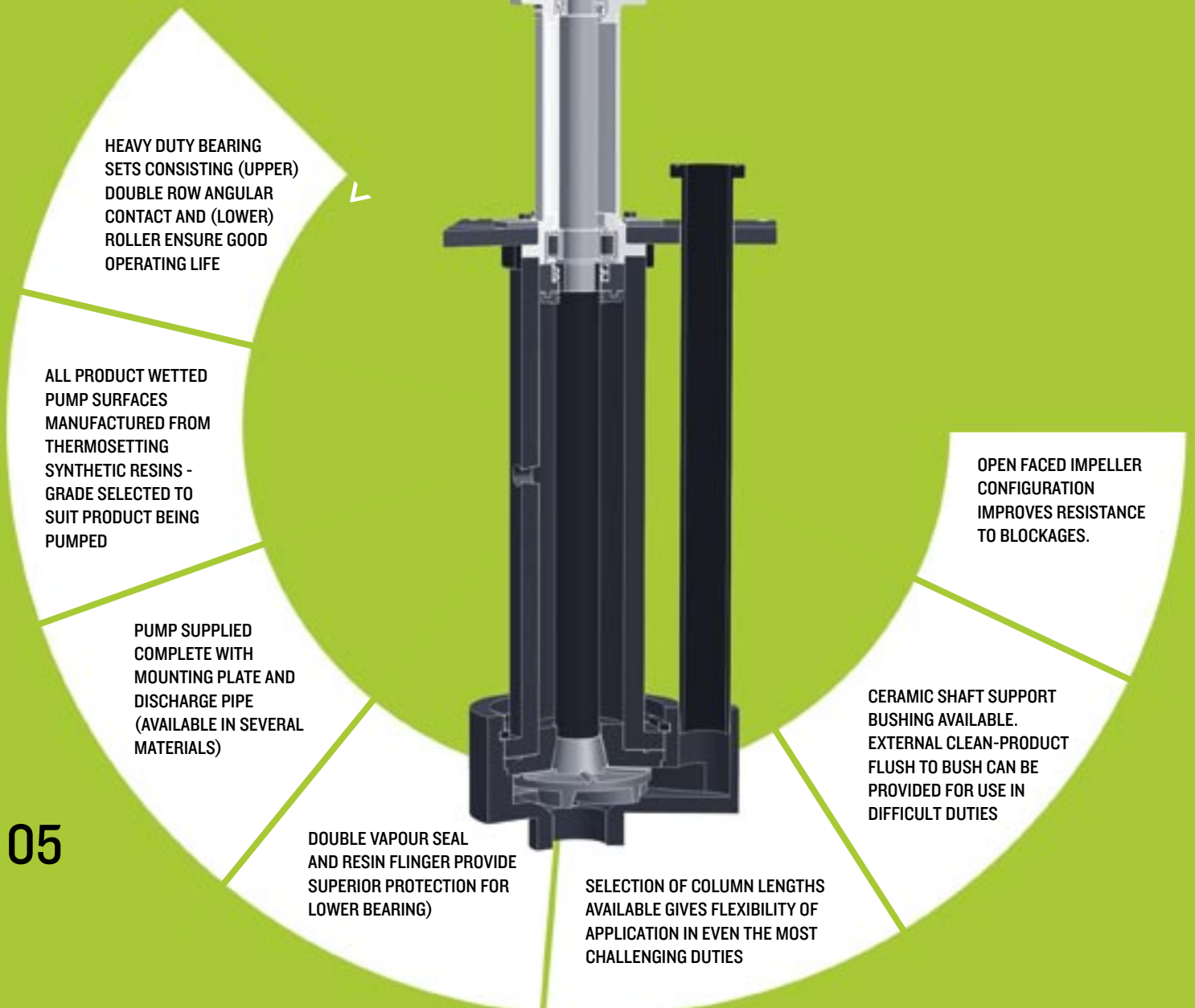

/ CRP SERIES CCH MKII

Our most demanded pump is the close coupled MkII. This robust pump is of end suction back pull-out design and provides the compact simplicity of a close coupled pump without compromising reliability. Great care has been taken to ensure that the impeller to bearing-set relationship provides excellent rotating assembly, while the standard use of a premium quality electric motor ensures optimal thrust control and good bearing life and maximises

mechanical seal performance. Of primary importance in a chemical pump, all wetted parts are in our corrosion resistant thermosetting resins and all non-motor fasteners are in stainless. An added feature which improves reliability and longevity in harsh environments is the use of resin for motor adaptor and base and the installation of a resin labyrinth to protect the motor.

/ FEATURES

This pump is available in the full range of sizes and up to 250 S/M motor frame size.

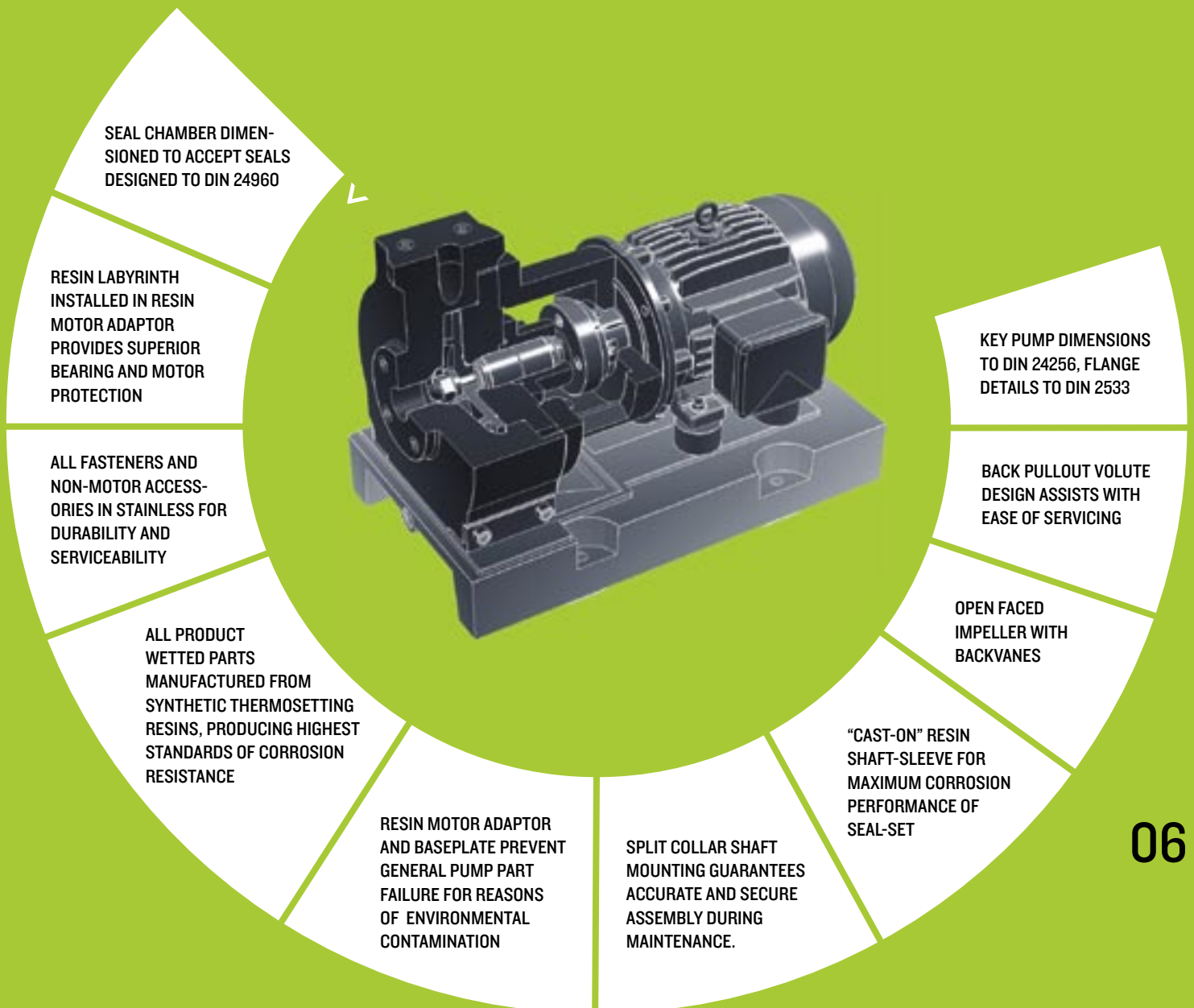

/ MECHANICAL SEALS

The shaft seal of a chemical pump is, more often than not, found to be the weak link that limits pump service life. In recognising this, and in understanding well those factors that can affect seal performance, Pacificchem Pumps have provided a seal chamber design that is both functionally correct and versatile. Dimensioned in to suit seals with installation dimensions to DIN 24960, the intelligent use

of the resin materials of construction allow full advantage to be gained from an array of common seal configurations.

The seals fitted as standard are supplied by an internationally respected sealing system manufacturer.

/ STANDARD SEALING CONFIGURATIONS

1 / Single Outside Seal



2 / Single Inside Seal



3 / Back-to-back Double Seal



4 / Cartridge Seal



/ PERFORMANCE

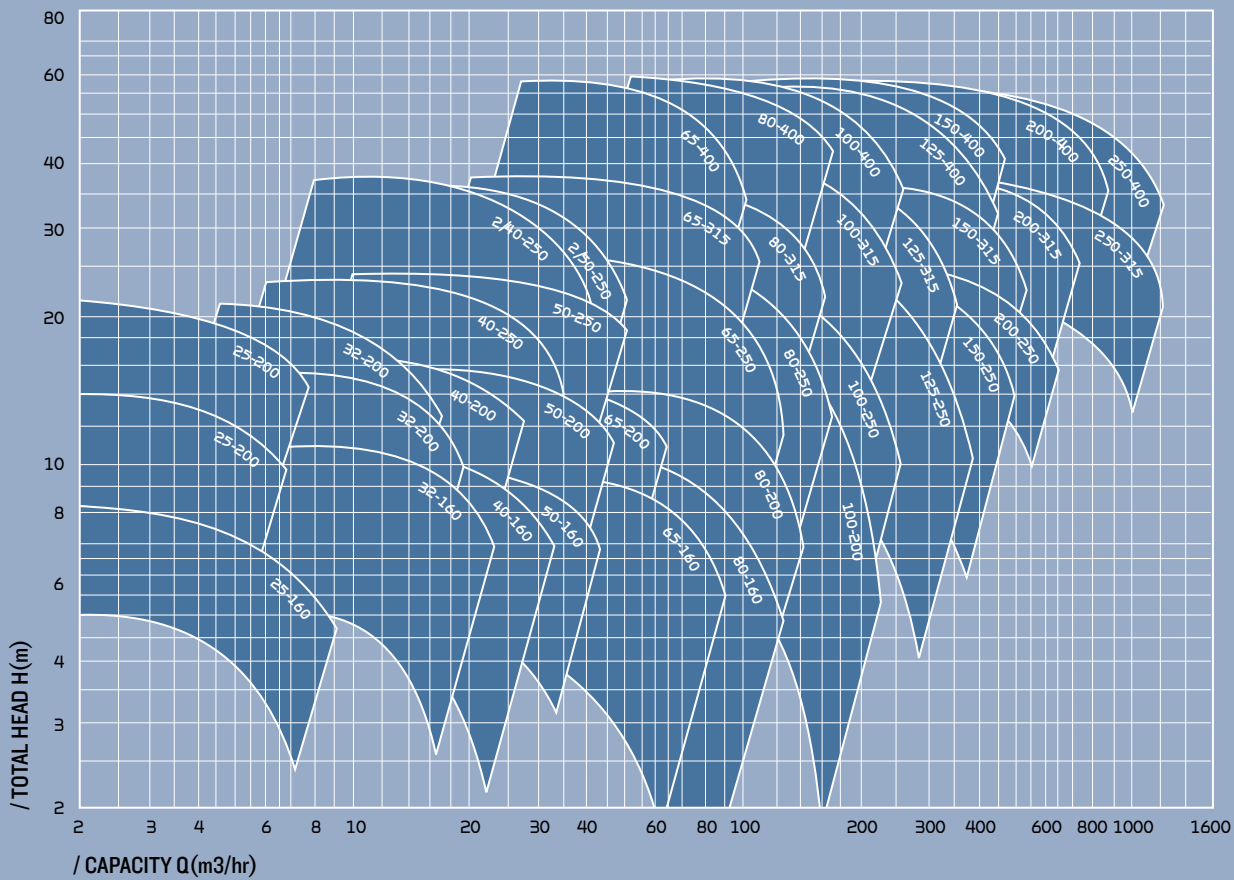

HYDRAULIC PERFORMANCE 1450RPM

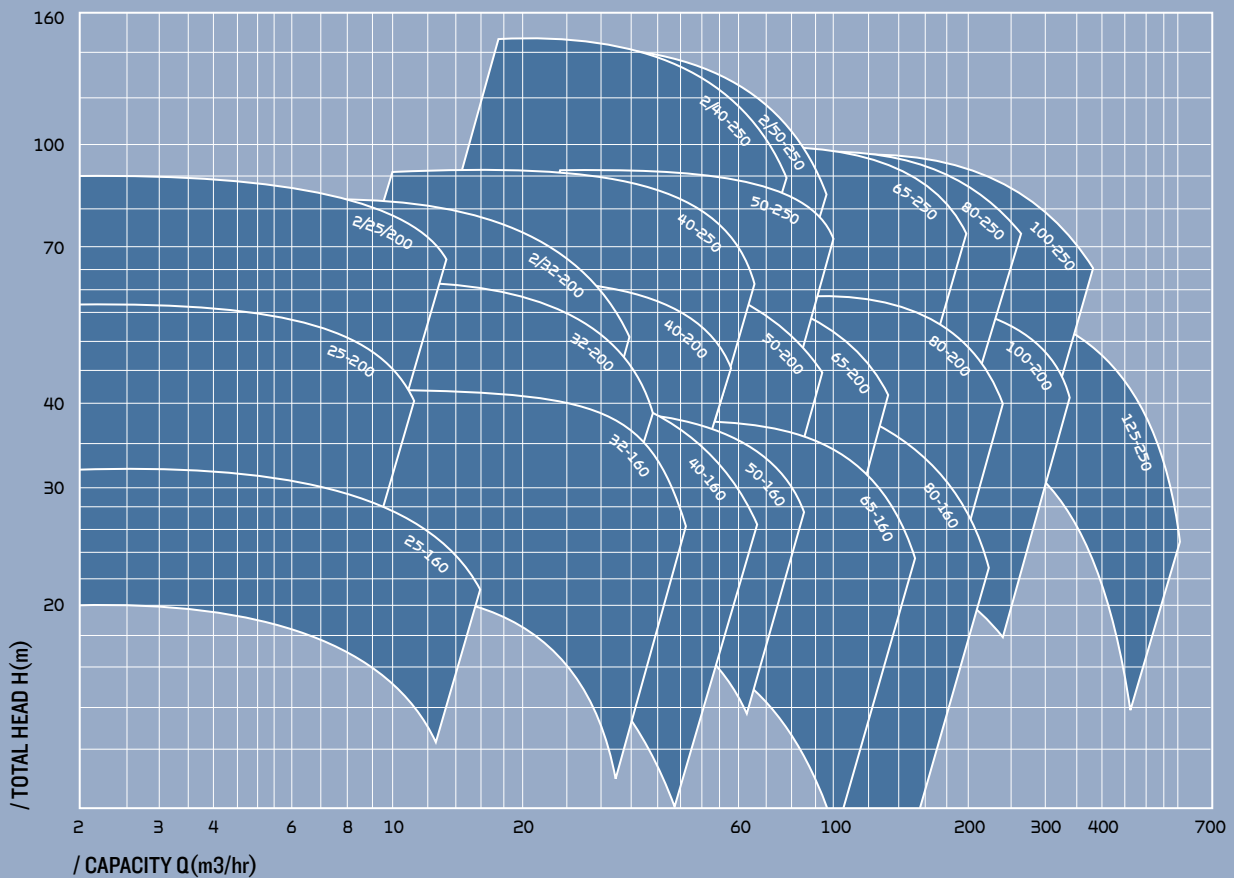

HYDRAULIC PERFORMANCE 2900RPM

PACIFICHEM™

/ NEW ZEALAND

T (+64 9) 579 9917

F (+64 9) 579 9918

E info@pacifichempumps.co.nz

/ AUSTRALIA

T (+61 3) 9674 0330

F (+61 3) 9699 7249

E info@pacifichempumps.com.au

/ DISTRIBUTOR